

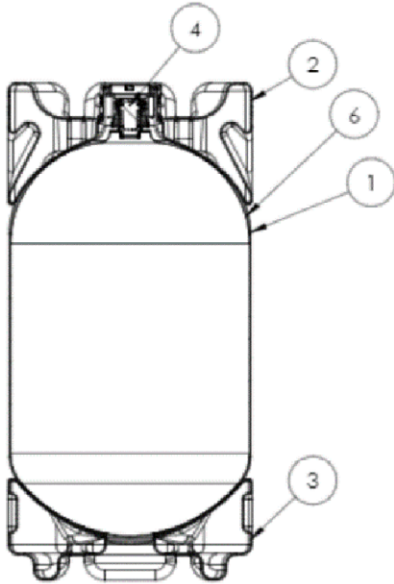

# FIRST ELEMENT KEGS

## SK-30

The SK-30 brings a lightweight, re-usable, sustainable keg system with a patented pressure relief system



MATERIALS	RECYCLE CODE	
Valve (4)	#5	PP/PC/SS
Seals (4)	#1	TPE
Patented Pressure Relief Cap (PRS)	#7	PC
Bag (6)	#4	Liquipure Ultra™ Polyethylene Film
End Caps (2&3)	#2	HDPE
Bottle (1)	#1	PET
Strap Supports	#1	PP

DIMENSIONS	
Diameter	12.79" (12" nested)
Height	24.53" (23.28" nested)
Weight	6.05lbs.
Volume	30L (7.93 US Gallon)
SHELF LIFE	
Filled	9 months
O2 Transmission Rate	.03 cc/100in2 /24hr.
SAFETY	
MAWP	60psi plus or minus 5psi
Burst Rating	100 PSI
PALLETIZATION	
Empty	(48"x48") - 48 units Horizontal (8/layer) or vertical (16/layer) 390lbs Floor to top of pallet 102" (excl pallet)
Full	32 units 2306 -2882lbs
DISPENSING	
Orientation	Vertical or horizontal dispensing
Pressurization	Any compressed inert gas (incl air)